

<b>Toucan Duo</b>	
Working Height	6.00 m
Platform Height	4.00 m
Platform Capacity <sup>1</sup>	130 kg
Elevating Shelf Capacity	70 kg
A1. Platform Size (L x W)	0.65 m / 0.75 m
A2. Elevating Shelf Size (L x W)	0.50 m / 0.75 m
B. Overall Width	0.78 m
C. Stowed Height	1.79 m
D. Overall Length	1.65 m
E. Wheelbase	1.35 m
F. Ground Clearance	8 cm
Chassis Width	0.78 m
Machine weight *	1,000 kg
Maximum Ground Bearing Pressure	13.10 kg/cm <sup>2</sup>
Drive Speed - Lowered	4 km/h
Drive Speed - Elevated	1 km/h
Turning Radius (outside)	1.64 m
Turning Radius (inside)	0.00 m
Gradeability	20%
Tyres (non-marking solid)	300 x 80
Electrical system	24V DC
Batteries	24V - 180A/hr
Dual Voltage 110/240V Charger	24V - 15A
Drive motors	2 motors 24V AC - 320 W
Brakes	Electromagnetic
Electrical motor	1 kW
Hydraulic system	6.0 L

**JLG Model Toucan Duo**

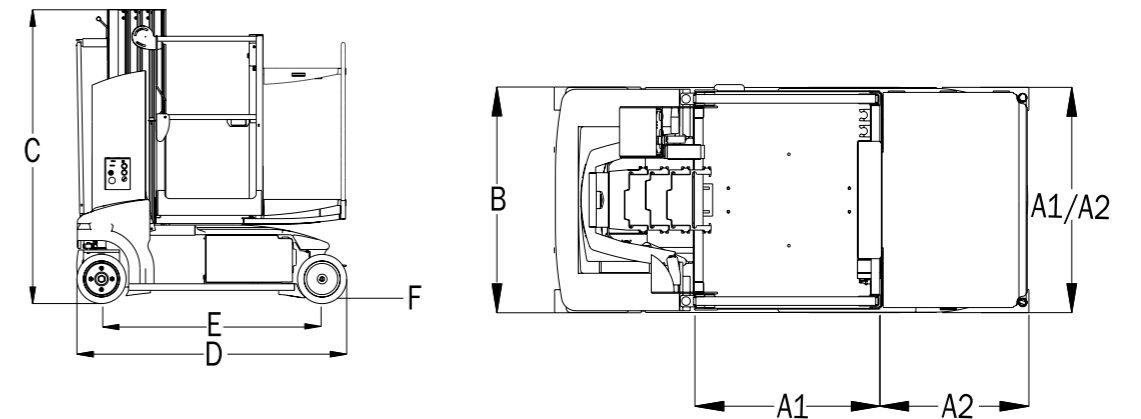

<sup>1</sup> Capacities shown are for 1 person indoors only  
 \* Certain options or country standards may increase weight and/or dimensions.

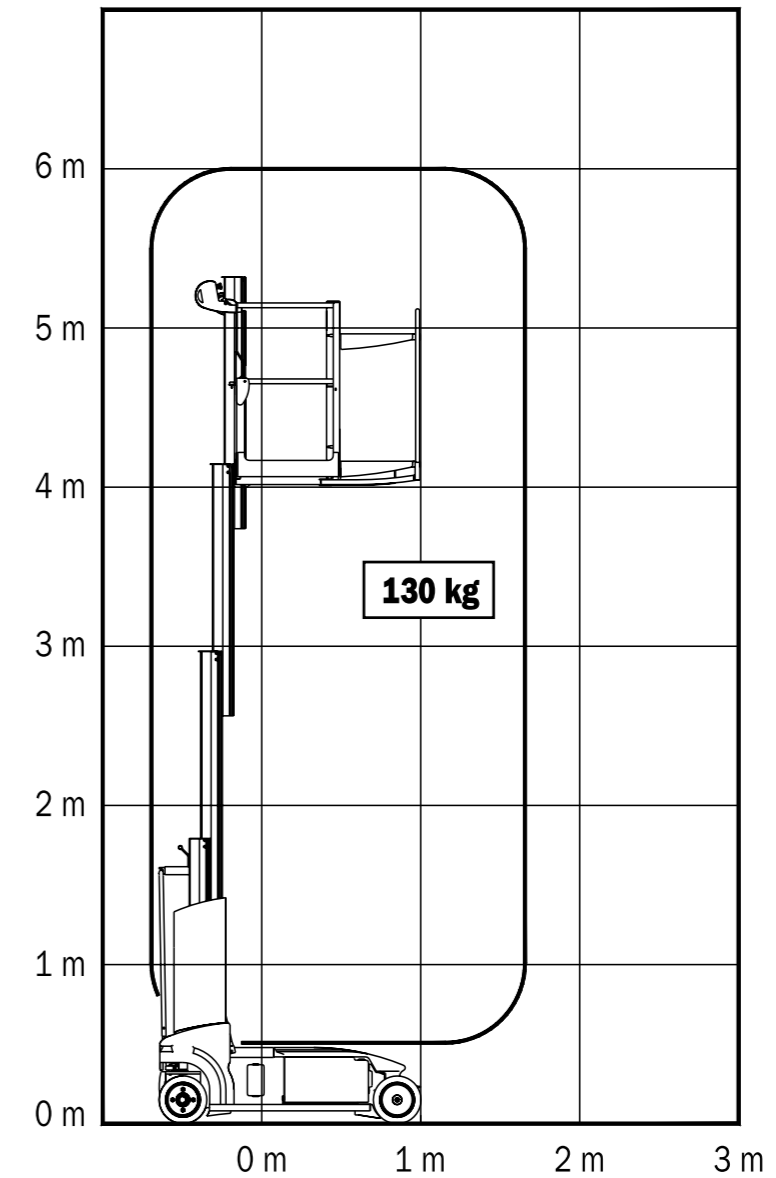