

	Toucan 10E	Toucan 10EL	Toucan 12E	Toucan 12E Plus
Working Height	10.10 m	10.10 m	11.83 m	12.65 m
Platform height	8.10 m	8.10 m	9.83 m	10.65 m
Working outreach (standard platform)	3.38 m	3.38 m	5.10 m	6.05 m
Up and over height	6.51 m	6.51 m	7.12 m	7.12 m
Swing (not continuous)	345°	345°	345°	345°
Platform capacity <sup>1</sup>	200 kg	200kg	200 kg	200 kg
Jib - overall length	1.60 m	1.60 m	3.19 m	4.14 m
Jib - range of articulation	127° (+66° / -61°)	126° (+65° / -61°)	120° (+60° / -60°)	120° (+60° / -60°)
A. Platform size standard platform (L x W)	0.70 x 0.90 m	0.70 x 0.90 m	0.70 m x 1.05 m	0.70 m x 1.05 m
Platform size XL platform (L x W)	—	—	—	—
B. Overall width	0.99 m	0.99 m	1.20 m	1.20 m
C. Tailswing	13 cm	12 cm	13 cm	13 cm
D. Stowed height	1.99 m	1.99 m	1.99 m	1.99 m
E. Overall length (standard platform)	2.82 m	2.82 m	3.65 m	3.65 m
Overall length (XL platform)	—	—	—	—
F. Wheelbase	1.20 m	1.20 m	1.60 m	1.60 m
G. Ground clearance	10.5 cm	10 cm	10 cm	10 cm
Machine weight - standard platform <sup>2</sup>	2,990 kg	2,600 kg	4,300 kg	4,900 kg
Maximum ground bearing pressure	21 kg/cm <sup>2</sup>	19.7 kg/cm <sup>2</sup>	12.5 kg/cm <sup>2</sup>	14.0 kg/cm <sup>2</sup>
Drive speed - lowered	5.5 km/h	5.5 km/h	6.0 km/h	6.0 km/h
Drive speed - elevated	0.75 km/h	0.75 km/h	0.75 km/h	0.75 km/h
Drive speed - full elevation	0.40 km/h	0.40 km/h	—	—
Turning radius (outside)	1.99 m	1.99 m	2.60 m	2.60 m
Turning radius (inside)	0.55 m	0.55 m	0.75 m	0.75 m
Gradeability	25%	25%	30%	30%
Break over angle	25%	25%	25%	25%
Steer angle	60°	60°	60°	60°
Max. allowable tilt angle	2°	2.5°	3°	3°
Tyres (non-marking solid)	406 x 125 mm	406 x 125 mm	457 mm x 178 mm	457 mm x 178 mm
Electrical system	24V DC	24V DC	48V DC	48V DC
Batteries (deep cycle)	24 V - 260 Ah AGM	24 V - 260Ah / AGM	48 V - 260 Ah / Naß	48 V - 260 Ah / Naß
Charger	24V - 27A	24V - 27A	48V - 25A	48V - 25A
Drive motors	Dual AC motors	Dual AC motors	Dual AC motors	Dual AC motors
Brakes	Disc	Disc	Disc	Disc
Electrical (pump) motor	3 kW 24V DC	3kW 24V DC	3.5 kW - 48V DC	3.5 kW - 48V DC
Hydraulic system	9.0 L	7,5L	15.0 L	15.0 L
Peter Hird cycles	92	80	80	74

JLG Model Toucan 10E & 10EL

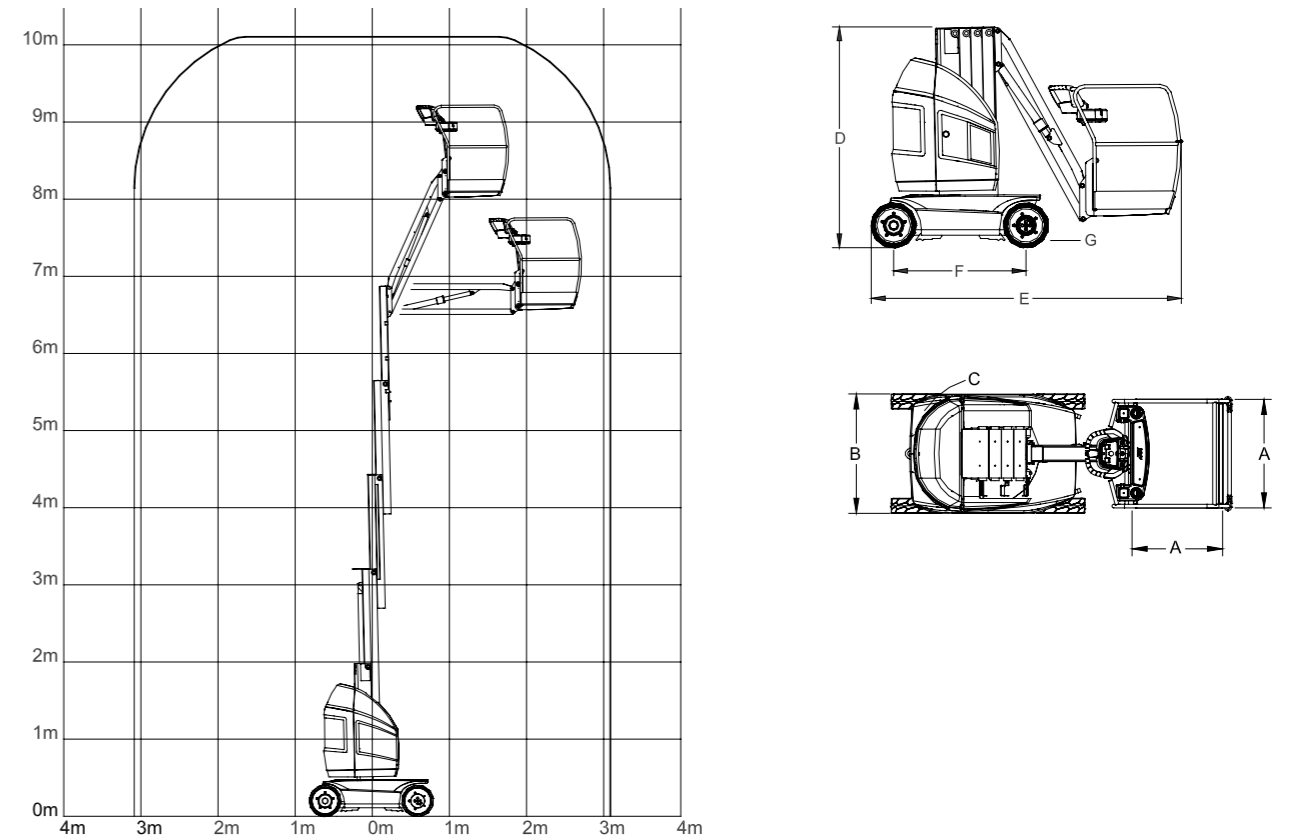

JLG Models Toucan 12E & 12E Plus

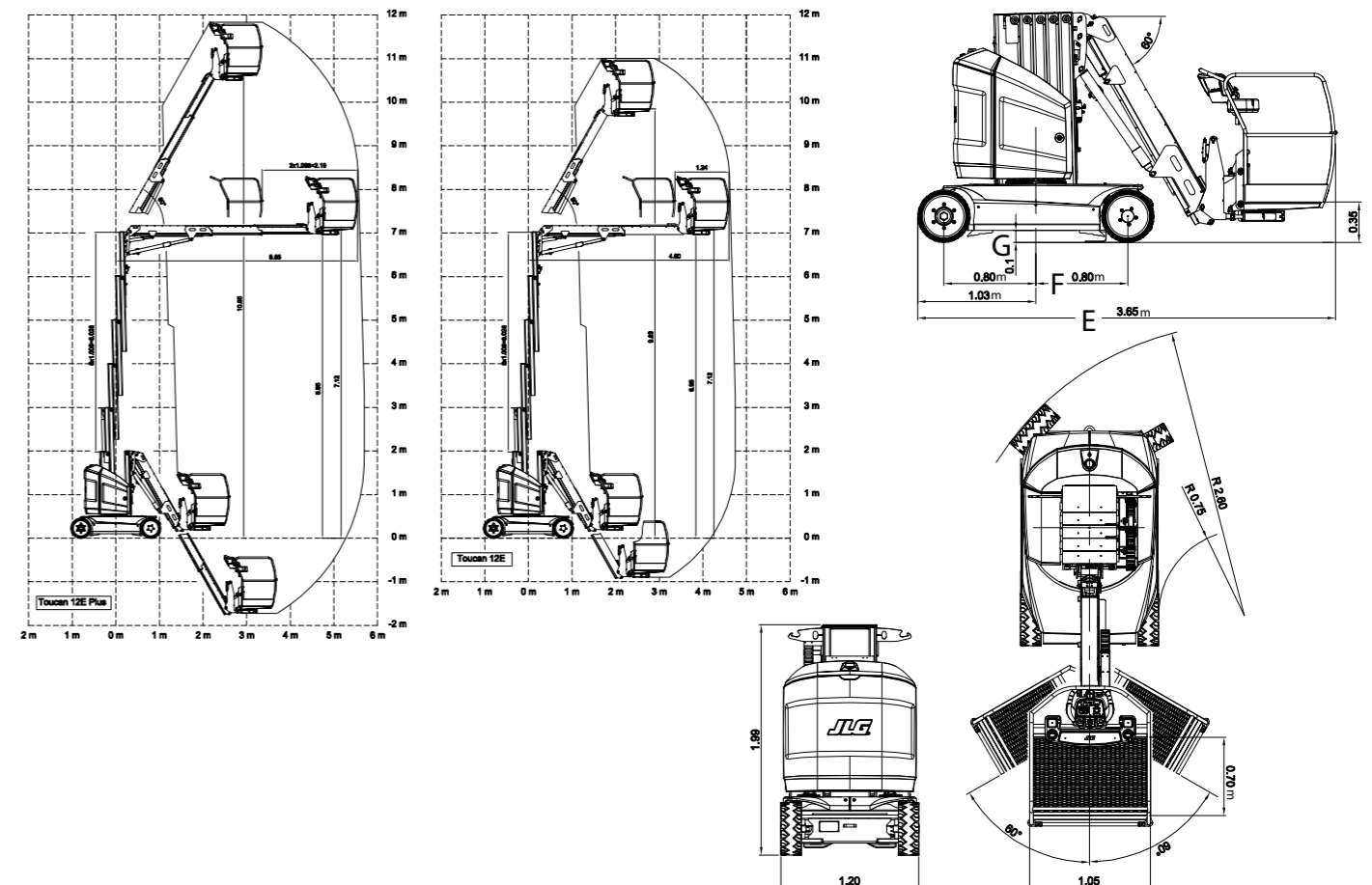

**EAZIACCESS** RENTAL | SALES | SERVICE | TRAINING  
086 100 3294 | www.eazi.co.za

<sup>1</sup> Capacity shown is maximum two persons indoor and outdoor (12.5 m/s wind speed)  
<sup>2</sup> Certain options or country standards may increase weight and/or dimensions.

