

	E300AJ	E300AJP
Working Height	11.19 m	10.97 m
Platform Height	9.19 m	8.97 m
Horizontal Outreach	6.17 m	6.12 m
Working Outreach *	6.82 m*	6.77 m*
Up and Over Height	4.01 m	4.01 m
Swing (non-continuous)	350°	350°
Platform Capacity - Unrestricted	230 kg	230 kg
Platform Rotator (Hydraulic)	180°	180°
Jib - Overall Length	1.22 m	1.22 m
Jib - Range of articulation	144° Vertical (+84°/ -60°)	144° Vertical (+84°/ -60°)
JibPLUS® - Range of Articulation	—	180° Horizontal
A. Platform Size	0.76 m x 1.22 m	0.76 m x 1.22 m
B. Overall Width	1.22 m	1.22 m
C. Tailswing (working condition)	Zero	Zero
D. Stowed Height	2.01 m	2.01 m
E. Stowed Length	5.54 m	5.74 m
F. Wheelbase	1.65 m	1.65 m
G. Ground Clearance	0.10 m	0.10 m
Machine weight ¹	6,900 kg	7,100 kg
Maximum Ground Bearing Pressure	11.95 kg/cm ²	11.95 kg/cm ²
Drive Speed	7.2 km/h	7.2 km/h
Gradeability	25%	25%
Tyres	25 x 7-12 Non marking	25 x 7-12 Non marking
Turning Radius - Inside	1.52 m	1.52 m
Turning Radius - Outside	3.10 m	3.10 m
Electrical System	48V AC	48V AC
Batteries	8 x 6V 305A/hr	8 x 6V 305A/hr
Drive Motors	Dual AC Traction	Dual AC Traction
Brakes	Automatic Spring Applied	Automatic Spring Applied
Hydraulic Motor	Perm. Magnet	Perm. Magnet
Hydraulic Pump	Gear Pump	Gear Pump
Hydraulic System	23.0 L	23.0 L

JLG Model E300AJ

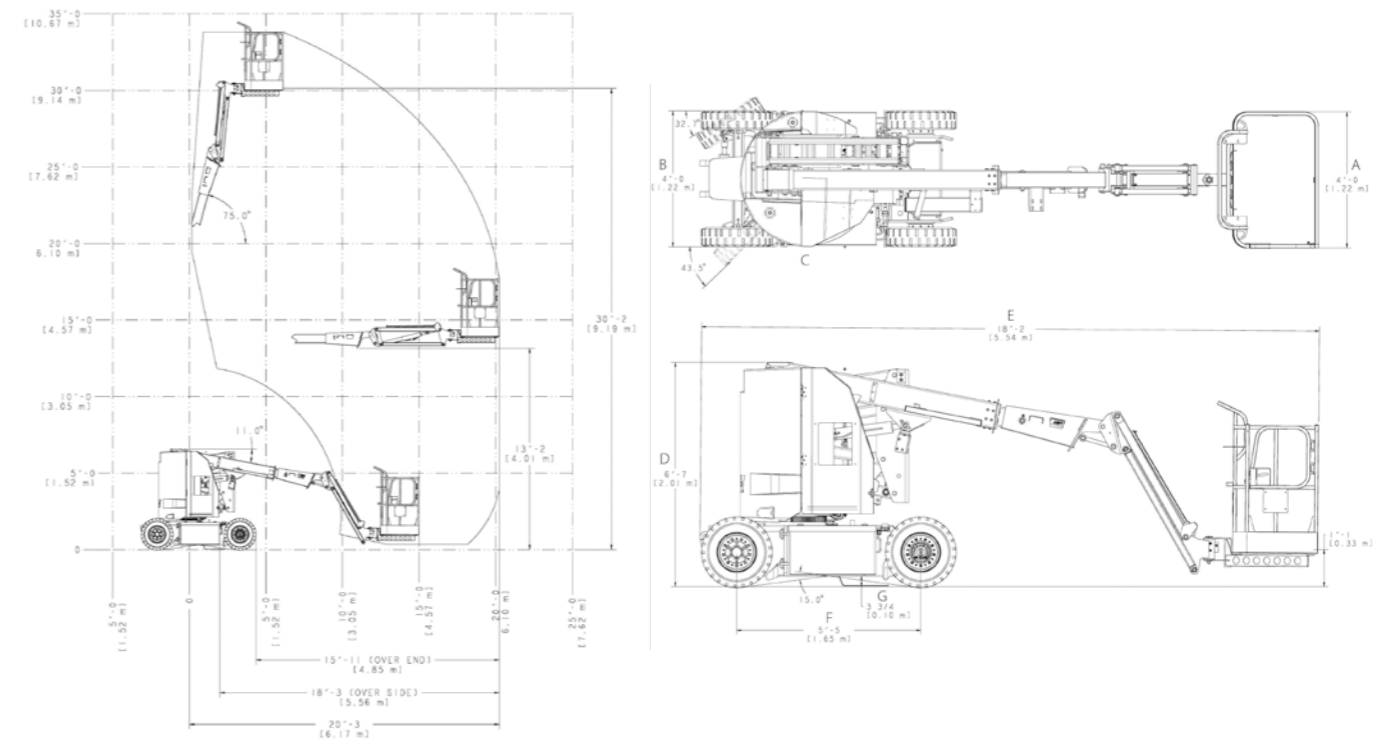

JLG Model E300AJP

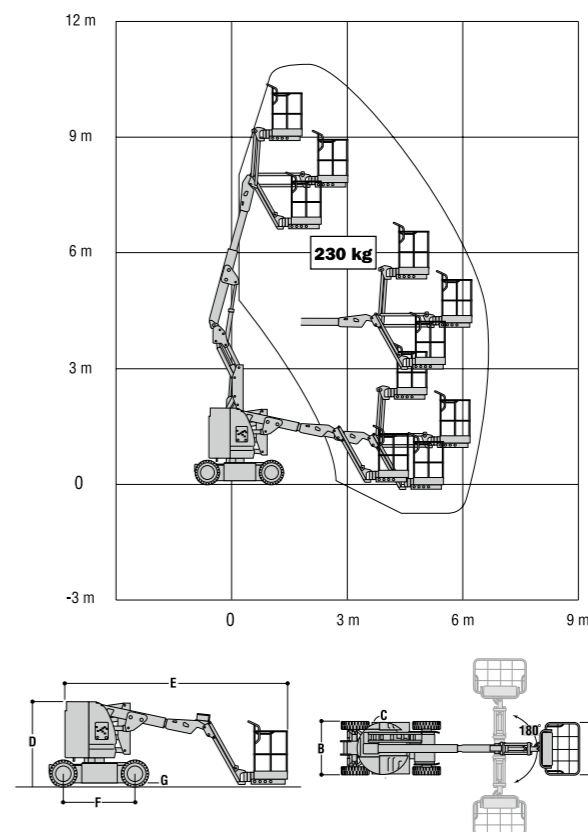

* Working outreach is horizontal outreach plus 65cm.
¹ Certain options or country standards may increase weight and/or dimensions.

